

Molecular Aspects of Hepatocellular Carcinoma Caused by Hepatitis C Virus

Ali Karami ^{1*}, Seyed-Moayed Alavian ², Ali Najafi ¹, Mohammad Javad Hosseini ¹

¹ Reserch Center of Molecular Biology, Baqiyatallah University of Medical Sciences, Tehran, Iran

² Liver and Gastrointestinal Research Center, Baqiyatallah University of Medical Sciences and Tehran Hepatitis Center, Tehran, Iran

The hepatitis C virus (HCV) is a small, enveloped, single-stranded positive-sense RNA virus with a diameter of about 50 nm belonging to the Hepacivirus genus of the family Flaviviridae. The HCV genome is translated to produce a single protein of around 3011 amino acids. This "polyprotein" is then proteolytically processed by viral and cellular proteases to produce structural (core protein, envelope glycoproteins E1 and E2, ARFP/F protein, p7) and nonstructural (NS2-3 autoprotease, NS3-4A, NS4B, NS5A, NS5B) proteins. Hepatocellular carcinoma (HCC) is one of the most frequent malignant tumors worldwide, with increasing incidence. It is estimated that approximately 300-400 thousands of people in the IRAN and 4 million in the United States are persistently infected. It is important for tumor control to identify the factors that predispose patients to death. A large number of molecular factors have been shown to associate with the invasiveness of HCC, and have potential prognostic significance.

Keywords: Hepatitis C Virus (HCV), Hepatocellular Carcinoma, Genomic and Proteomics

Introduction

Hepatitis C virus (HCV) infection afflicts more than 170 million people worldwide, with the great majority (~85%) of patients developing chronic HCV infection. Co-infection with HIV is common and rates among HIV positive populations are higher. It can ultimately result in liver cirrhosis, hepatic failure or hepatocellular carcinoma, which is responsible for hundreds of thousands of deaths each year. It is estimated that approximately 300-400 thousands of people in Iran and 4 million in the United States are persistently infected. Peak prevalence of HCV infection occurs among persons 40 to 49 years of age. The chronic HCV infection carries an increased risk of developing fatal liver diseases such as cirrhosis, liver failure, and hepatocellular carcinoma ^(1, 2, 32).

Hepatocellular carcinoma (HCC) is one of the most frequent malignant tumors worldwide, with increasing incidence. Only a minority of patients are amenable to surgery (partial hepatectomy or transplantation), which represents the only treatment with curative potential thus far. Alternative therapeutic prospects for HCC are restricted because local therapy, such as ethanol injections or thermoablation, may only be effective in localized small HCCs, which are present only in

a minority of patients. Different macroscopic and histological growth patterns of HCC have been classified, but these classifications are not of mechanistic, therapeutic, or prognostic impact. Thus, conventional grading and staging are currently the only tumor parameters of significant prognostic impact. Therefore, a molecular classification of HCCs may lead to improved mechanistic understanding and the identification of novel markers ^(10, 33, 34).

Most patients with chronic hepatitis have asymptomatic elevations of serum transaminases in absence of any physical signs of liver disease. Only about 6% of patients have symptomatic liver disease. Fatigue and dull ache in right hypochondrium are two common symptoms. Physical examination is more helpful once cirrhosis has developed. Serum ALT levels are usually only mildly elevated. One third of patients have normal ALT levels, whereas only about 25% have a level

* Correspondence:

Ali Karami Ph.D, Associate Professor of Molecular Biology, P.O. Box: 19945-581, Tehran, Iran.

Tel: +98 21 88039883

Fax: +98 21 88057023

E-mail: Karami@bmsu.ac.ir

Hep Mon 2006; 6 (2): 75-82

more than twice normal. However, there is a wide variability in enzyme elevation when patients are followed for a long time. Patients with normal enzymes may have definite chances of chronic hepatitis on histological examination. Similarly the level of HCV RNA correlates poorly with histology.

The course of chronic hepatitis is a slow one marked by fluctuating transaminases over many years. Some observers have detected more rapid progression of hepatitis C in patients older than 50 years. Co factors such as concomitant alcoholism, chronic hepatitis B or hemochromatosis may be important contributors to progressive liver disease in patients with hepatitis (27, 36).

Cirrhosis of liver and hepatocellular carcinoma are two dreaded complications of chronic HCV infection. HCV and HIV infection may co-exist especially in drug abusers and hemophiliacs and this may cause severe, accelerated liver disease. Hepatitis C virus (HCV) is known to be a human carcinogen based on sufficient evidence from studies in humans. Numerous cohort and case-control studies conducted in populations differing by race or ethnicity and in various geographical locations have demonstrated that chronic HCV infection causes a malignant tumor of the liver (hepatocellular carcinoma). The annual risk of HCC is 1.4% in cirrhotic patients in the United States and most of Europe in Tokyo 83% of patients with HCC are already infected with HCV. In comparison, only 10% are infected with HBV. The mean duration of HCV infection in patients with HCC is 28 to 29 years. It is probable that the ongoing process of hepatocyte necrosis and liver cell renewal coupled with inflammation, which is characteristic of chronic viral hepatitis, causes not only regeneration and cirrhosis but also progressive genomic errors in hepatocytes as well as unregulated growth and repair mechanisms leading to dysplasia and, in some cases, hepatic carcinoma (27, 37).

Virology of HCV

HCV is a small, enveloped, single-stranded positive-sense RNA virus with a diameter of about 50 nm belonging to the *Hepacivirus* genus of the family *Flaviviridae*. The 9.6-kb RNA genome encodes a single polyprotein that play important roles in virus entry, replication, assembly, and pathogenesis. The sequence and structures of the untranslated regions (UTR) at both the 5' and 3' ends of the HCV RNA genome, which contain *cis-*

acting RNA elements required for HCV RNA translation and replication, are highly conserved (3, 4).

HCV mainly replicates within hepatocytes in the liver, although there is clear evidence for replication in lymphocytes or monocytes. Circulating HCV particles bind to receptors on the surfaces of hepatocytes and subsequently enter the cells. Two putative HCV receptors are CD81 and human scavenger receptor class B1 (SR-BI). However, these receptors are found throughout the body. The identification of hepatocyte-specific cofactors that determine observed HCV liver tropism are currently under investigation (3, 5).

Once inside the hepatocyte, HCV utilizes the intracellular machinery necessary to accomplish its own replication. Specifically, the HCV genome is translated to produce a single protein of around 3011 amino acids. This "polyprotein" is then proteolytically processed by viral and cellular proteases to produce structural (virion-associated) and nonstructural (NS) proteins. Alternatively, a frameshift may occur in the Core region to produce an Alternate Reading Frame Protein (ARFP).

HCV has a high rate of replication with approximately one trillion particles produced each day in an infected individual. Due to lack of proofreading by the HCV RNA polymerase, HCV also has an exceptionally high mutation rate, a factor that may help it elude the host's immune response (3, 31) (figure 1)

Molecular Analysis of the HCV Genome

The genomic organization of HCV is shown schematically in figure 2. Organization of HCV

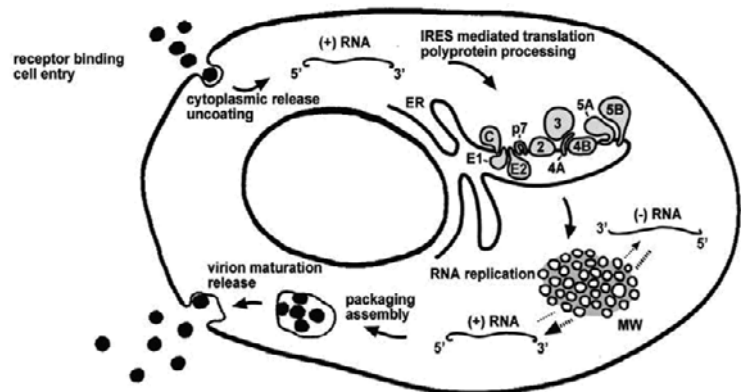

Figure 1. Life cycle of HCV. The steps of the viral life cycle are depicted schematically. The topology of HCV structural and nonstructural proteins at the endoplasmic reticulum (ER) membrane is shown. HCV RNA replication occurs in a specific membrane alteration, the membranous web (MW). IRES-mediated translation and polyprotein processing as well as membranous web formation and RNA replication, illustrated here as separate steps for simplicity, may occur in a tightly coupled manner.

RNA indicates that the virus is closely related to the pestivirus genera within the family, Flaviviridae, but has now been classified in its own subgenera Hepacivirus. The viral genome is a single-stranded RNA molecule approximately 9.5 kb in length that is positive sense and possesses a unique open-reading frame, coding for a single polyprotein. The viral genome is flanked by untranslated regions (UTRs) at its 5' and 3' ends. Apart from differences in length, HCV genotypes (subfamilies) show diversities of approximately 30% in the nucleotide sequences of their whole, showing at least 6 genotypes and more than 30 subtypes throughout the world. The importance of the genomic heterogeneity is that some genotypes appear to be associated with more severe pathological states and are more refractory to treatment. Genotyping is becoming a common clinical assay in the management of newly diagnosed HCV, but not during clinical flare or after liver transplantation (5, 6, 9, 35).

Molecular Aspects of Viral Proteins

Structural proteins

Core protein

The protein located at the amino terminus of the polyprotein is highly basic in nature and considered likely to be the viral core (nucleocapsid) protein. It is released from the viral polyprotein by nascent proteolytic cleavage at amino acid 191 by cellular, not viral, proteases. The subcellular trafficking of the core protein has been an area of interest. In particular, the nucleolar localization of core may be caused by its ability to bind to ribosomes assembled in the nucleus. The biological functions of the core

protein found in the nucleus, if this also occurs in natural virus replication, are still unclear. Of note, the core protein has been reported to interact with numerous cellular proteins and to affect host cell functions such as gene transcription, lipid metabolism, apoptosis and various signaling pathways. Further, it has been associated with the induction of steatosis and HCC (5, 25).

Envelope glycoproteins

The envelope glycoproteins E1 and E2 are type I transmembrane proteins with C-terminal hydrophobic anchors. The ectodomains translocate to the ER lumen where they are modified by extensive N-linked glycosylation. E1 and E2 form non-covalent heterodimers which are believed to represent the building blocks for the viral envelope. The processes of particle assembly and release are poorly understood and have only recently become amenable to systematic investigation. In this context, structural studies on recombinant HCV particles confirmed earlier electron microscopy observations.

The two HCV envelope glycoproteins E1 and E2 are released from HCV polyprotein by signal peptidase cleavages. These glycoproteins are type I transmembrane proteins with a highly glycosylated N-terminal ectodomain and a C-terminal hydrophobic anchor. After their synthesis, HCV glycoproteins E1 and E2 associate as a noncovalent heterodimer. The transmembrane domains of HCV envelope glycoproteins play a major role in E1-E2 heterodimer assembly and subcellular localization. The envelope glycoprotein complex E1-E2 has been proposed to be essential for HCV entry. However, for a long time, HCV entry studies have limited by the lack of a robust cell culture system for HCV replication and viral particle production. Recently, a model mimicking the entry process of HCV lifecycle has been developed by pseudotyping retroviral particles with native HCV envelope glycoproteins, allowing the characterization of functional E1-E2 envelope glycoproteins. Here, we review our understanding to date on the assembly of the functional HCV glycoprotein heterodimer (3, 5).

ARFP/F protein

The synthesis of a protein encoded by an alternative reading frame within the core region was reported by several groups. It was designated ARFP (alternative reading frame protein) or F (frameshift) protein and comprises up to 160 amino acids. The

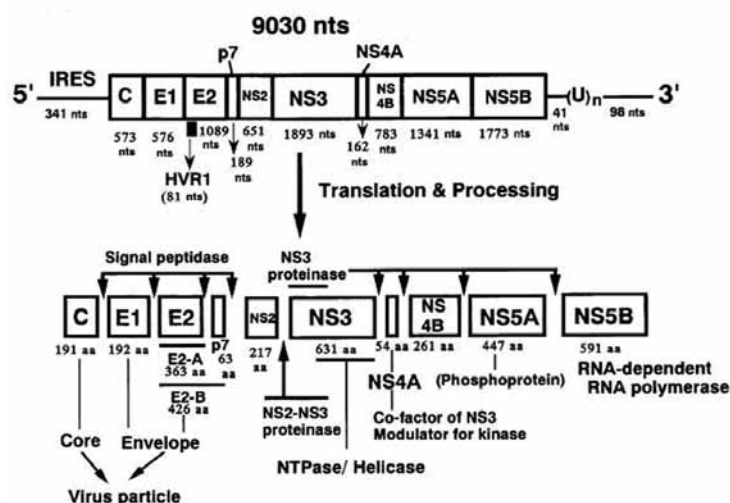

Figure 2. Structure of HCV genome and summary of HCV polyprotein processing.

ARFP/F protein is dispensable for HCV RNA replication. Whether it is expressed during natural HCV infection has still to be clarified (3).

P7 protein

This protein is a 63 amino acid polypeptide located at the junction between the structural and nonstructural region. It is unknown whether p7 is packaged into viral particles. It is composed of two transmembrane domains and has recently been reported to form hexamers with ion channel activity. It is believed that p7 could be important for viral assembly because the corresponding protein of the related bovine viral diarrhea virus (BVDV) is essential for the production of infectious progeny virus but not for RNA replication (3).

Nonstructural proteins

NS2-3 autoprotease

The NS2/3 junction is cleaved by a remarkable autoprotease consisting of NS2 and the N-terminal third of NS3. Although NS2-3 protease activity is required for the replication *in vivo*, it is not necessary for replication of subgenomic replicons *in vitro*. It is unclear whether NS2 fulfills any further functions after separation from NS3.

The hepatitis C virus NS2/3 protein is a highly hydrophobic protease responsible for the cleavage of the viral polypeptide between non-structural proteins NS2 and NS3. However, many aspects of the NS2/3 protease role in the viral life cycle and mechanism of action remain unknown or controversial. NS2/3 has been proposed to function as either a cysteine or metalloprotease despite its lack of sequence homology to proteases of known function. In addition, although shown to be required for persistent infection in a chimpanzee, the role of NS2/3 cleavage in the viral life cycle has not yet been fully investigated due to the lack of an *in vitro* system in which to study all aspects of HCV replication. However, several recent studies are beginning to clarify possible roles of the cleaved NS2 protein in modulation of host cell gene expression and apoptosis (5, 6, 7, 9).

NS3-4A

NS3 is a multifunctional protein because it harbors a serine protease located in the N-terminal one-third that is responsible for the downstream cleavage in the nonstructural region and NTPase/RNA helicase domain in the C-terminal two-thirds. NS4A, a 54-amino acid polypeptide, targets NS3 to intracellular membranes and is

required as a cofactor for the NS3 serine protease.

The crystal structure of the NS3-4A complex revealed that NS4A is an integral component of the enzyme core. Surprisingly, the NS3 serine protease recently turned out to influence the innate cellular host defense by inhibition of RIG-I and TLR3 signaling. This observation renders the NS3 protease particularly attractive as an antiviral target. Serine protease inhibitors have emerged as extremely efficient antiviral components in first 'proof-of-principle' studies in patients with chronic hepatitis C. The enzymatic activity of the NS3 NTPase/helicase activity is indispensable for RNA replication. Putative functions during replication could be to unwind replicative double strand RNA intermediates, to eliminate RNA secondary structures or to separate the genome from nucleic acid binding proteins. Recent advances in the understanding of the molecular mechanisms of this enzyme could enable a specific inhibition as a novel antiviral strategy (5-9).

As mentioned before the 9.6 kb plus-strand RNA genome of HCV encodes a long polyprotein precursor of ~3,000 amino acids, which is processed by cellular and viral proteases to 10 individual proteins. One of the HCV proteases, NS3-4A serine protease, is a non-covalent heterodimer consisting of a catalytic subunit (the N-terminal one-third of NS3 protein) and an activating cofactor (NS4A protein), and is responsible for cleavage at four sites of the HCV polyprotein. HCV NS3-4A protease is essential for viral replication in cell culture and in chimpanzees, and has been considered as one of the most attractive targets for developing novel anti-HCV therapies. However, discovery of small-molecule, selective inhibitors against HCV NS3-4A protease as oral drug candidates has been hampered by its shallow substrate-binding groove and the lack of robust, reproducible viral replication models in cell culture or in small animals. Nevertheless, decade-long intense efforts by many groups have largely overcome these two obstacles and provided fruitful understanding of its biological functions, biochemistry, and three-dimensional structures, culminating in recent demonstration of proof-of-concept anti-HCV activities in patients. This chapter will review key findings in these areas, and focus on the discovery and clinical development of HCV NS3-4A protease inhibitors as novel antiviral therapies (7-9).

NS4B

Due to its very hydrophobic properties, NS4B belongs to the difficult-to-study HCV proteins that are poorly understood. So far, it is known that NS4B

is a 27-kDa integral membrane protein that localizes to an ER-derived membranous compartment. Interestingly, the expression of NS4B induces a specific membrane alteration, designated the membranous web that serves as a scaffold for the formation of the viral replication complex.

NS4B is a relatively hydrophobic membrane protein with size of 27 kDa which for many years was characterized mainly as a protein of unknown function. Recently, however, information about the protein and its involvement in mediating various viral activities and effects on host cells is beginning to accumulate. NS4B has been implicated in modulation of NS5B's RNA dependent RNA polymerase activity and various host signal transduction pathways, a possible role in HCV carcinogenesis, impairment of ER function, and regulation of both viral and host translation. Perhaps most significant, NS4B has recently been found to be responsible for the formation of a novel intracellular membrane structure, termed the membranous web, which appears to be the platform upon which viral replication occurs. Specific domains within NS4B have been identified which likely underlie the mechanisms employed by NS4B to mediate many of the preceding functions. As such, these domains which include an amphipathic helix and nucleotide-binding motif represent attractive targets for new antiviral strategies ⁽⁵⁾.

NS5A

The hepatitis C virus (HCV) non-structural 5A (NS5A) protein is a phosphorylated zinc metalloprotein of unknown function. Numerous potential functions and a huge list of interaction partners have been described. NS5A has initially attracted considerable interest because of its potential role in modulating the IFN response. These findings are still controversial, however. A striking observation was the concentration of cell culture adaptive replicon mutations within the central part of NS5A. Considering the fact that NS5A phosphorylation has an impact on replication efficiency, these observations support the concept that NS5A plays an important role in the regulation of viral replication. The membrane association of NS5A is mediated by a unique amphipathic alpha-helix which is localized at the N-terminus. Limited proteolysis experiments recently allowed the definition of three protein domains within the cytosolic domain. More recently, the three-dimensional structure of the N-terminal domain I could be resolved by crystallography. After dimerization, it forms a basic groove facing the cytosol at the surface of the membrane. This 'claw

like' structure is believed to provide an RNA binding site that could be involved in regulated genome targeting within the replication complex ^(3, 5).

NS5A exists as two forms of polypeptides p56 and p58 which are phosphorylated at serine residues, and phosphorylation occurs after the mature NS5A protein is released from the polyprotein. NS5A protein localizes in the nuclear periplasmic membrane. Apart from the probable role of NS5A in the virus replication cycle, it may play a critical role in determining the susceptibility of the virus to treatment with interferon (IFN). The sensitivity to IFN correlates with mutations within the discrete region of NS5A and is named the IFN sensitivity-determining region. Subsequent analysis suggested that the likely mechanism of IFN resistance occurs through a direct interaction of NS5A with the IFN-induced protein kinase, PKR. Since PKR is a critical factor in the response to IFN, its inactivation by NS5A may be a possible mechanism by which HCV evades the host immune response. However, the selective pressures exerted on HCV quasispecies during IFN therapy appear to differ among different patients. A recent study suggests that NS5A nucleotide and amino acid phylogenies did not correlate with clinical IFN responses and that the domains involved in NS5A functions *in vitro* were all well conserved before and during IFN treatment ^(5, 23, 26).

NS5B

The key enzyme of the replicase that promotes synthesis of new RNA genomes is the NS5B RNA dependent RNA polymerase (RdRp). NS5B is a tailanchored protein, characterized by a transmembrane domain at the C-terminus of the protein responsible for posttranslational membrane targeting. The structural organization of NS5B is a typical 'right hand' polymerase shape with finger, palm, and thumb subdomains surrounding a completely encircled active site. Replication proceeds *via* synthesis of a complementary minus-strand RNA using the genome as a template and the subsequent synthesis of genomic plus-strand RNA from this minus-strand RNA intermediate. As central component of the HCV replicase, NS5B has emerged as a major target for antiviral intervention ^(5, 7).

Molecular aspects of Hepatocellular Carcinoma

Hepatocellular carcinoma (HCC) is triggered by many factors including HCV infection. It is generally believed that the majority of cases of HCV

infection give rise to an acute illness up to 80% may develop into chronic hepatitis. Almost all patients develop a vigorous antibody and cell-mediated immune response which fails to clear the infection but may contribute towards liver damage. Most flavivirus infections are cytopathic, but this has not been directly tested in the case of HCV since the virus cannot be cultured. Spontaneous resolution of chronic liver disease is very rare (<2%) and patients with chronic disease are at risk of developing HCC. However, some studies have suggested that infection may have a more benign outcome, at least in some populations. Chronic HCV infection is a major risk factor for the development of hepatocellular carcinoma worldwide (8, 10, 11, 15, 28).

Prognostic factors in HCC conventionally consist of staging with the tumor node metastasis system (TNM) and grading by tumor cellular differentiation. There are also other factors useful in prognostic predication but most of them are clinical. With new discoveries in cancer biology, pathological and biological factors of HCC in relation to prognosis have been studied quite extensively. Morphological features of the tumor, both gross and histological, have been found to significantly associate with tumor recurrence and patient survival. A complementary way is to analyze molecular markers for their prognostic significance with reference to tumor recurrence and survival term in HCC. A large number of molecular biological factors have been shown to associate with the invasiveness of HCC, and have potential prognostic significance. However, routine biomarkers for the prediction of HCC prognosis are not yet available (12, 13, 14, 30).

NS5A protein transcriptionally down-regulates the cyclin-dependent kinase inhibitor p21/waf1 gene and promotes cell growth. Induction of p21/waf1 is a common mechanism of growth arrest in different physiological situations. p21/waf1 may participate in apoptosis, and increased p21/waf1 expression correlates with enhanced cell death under certain conditions. p21/waf1 is transiently induced in the course of replicative senescence, reversible and irreversible forms of damage-induced growth arrest, and terminal differentiation of postmitotic cells. The p53 tumor suppressor gene serves as a checkpoint in maintaining genomic stability, and p53 function is impaired in the majority of human cancers. p53 is a nuclear protein and consists of at least three functional domains: the N-terminal transcriptional activation domain, the central sequence-specific DNA binding domain, and the C-terminal oligomerization domain. The induction of p21/waf1 is regulated through p53-dependent and

independent mechanisms. p53 acts as a transcriptional activator and upregulates p21/waf1, leading to p53-dependent G1 arrest. Viral gene products target residues of the N terminus of p53 that are employed to interact with the transcriptional machinery of cells (20, 21, 22, 24, 25).

NS5A protein is associated with other viral-encoded proteins as part of the viral replicase complex on the cytoplasmic side of the endoplasmic reticulum. p53 transcription mediated via hTAFs (essential coactivators of p53 transcription), and p21 expression mediated by p53 proceed as normal, allowing apoptosis. During HCV infection, NS5A partially sequesters hTAF(II) 32 and hTAF(II) 28 in the cytoplasm. In addition, post-translational modifications of NS5A give rise to smaller molecular weight forms that are able to translocate to the nucleus and interact with TATA-box-binding protein (TBP), p53 and excision repair cross complementing factor 3 (ERCC3). These interactions lead to inhibition of p53 transcription and action, and thereby inhibit apoptosis. The HCV core protein has two forms: a mature form and an innate one formed by processing (4, 16, 17, 18). In the cytoplasm, the innate form binds to the mature form; formation of this heteromultimer prevents transportation of the mature form to the nucleus. In the cytoplasm the innate form activates p53, which in turn, as a transcription factor for p21, enhances the expression of p21. In the nucleus, the mature form reduces p21 expression by a pathway independent of p53. A core-responsive element overlaps the TGF- β /butyrate-responsive element on the p21 pathway; the core activates p21 by stimulating a butyrate pathway (19, 25).

Several studies have reported the suppression by core of transcription of several host immunoregulatory genes, as well as interference in expression of coinfecting genomes of hepatitis B56 and human immunodeficiency viruses. Perhaps the most interesting recent observations have been that core can specifically suppress apoptotic cell death in artificial systems and also specifically interact with the cytoplasmic tail of the lymphotoxin-b receptor, a member of the tumor necrosis factor family. Because lymphotoxin-b receptor is known to be involved in apoptotic signaling, this strongly suggests that core may have an immunomodulatory function and a critical role in the establishment of persistence and disease pathogenesis. Finally, a recent report shows an association between the core protein and the surface of lipid droplets within the cytoplasm. Analysis of the triglyceride populations within the cell indicates that core protein expression stimulates a change in cellular metabolism of

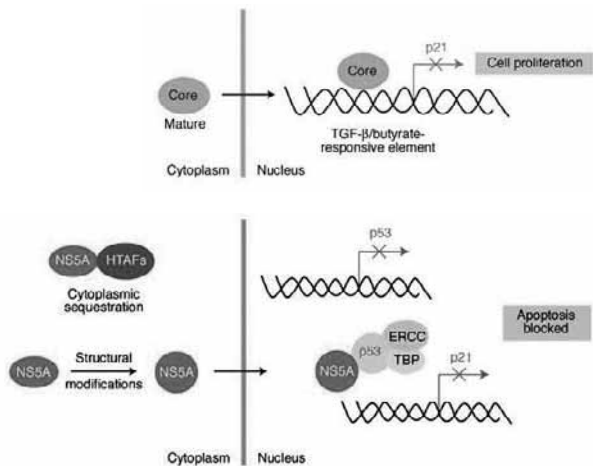

Figure 3. Possible model for HCV core & NS5A proteins by p53 interactions.

triglycerides. Because a characteristic of HCV infection is liver steatosis, it is plausible that this is a result of the direct effect of the core protein on lipid metabolism (23, 26).

Cellular malignancy is a very important aspect for patient prognosis. In recent years, with the development of cellular and molecular biological techniques, many molecular markers related to invasion, metastasis, recurrence and survival have been explored. The prognosis of hepatocellular carcinoma still remains dismal, although many advances in its clinical study have been made. It is important for tumor control to identify the factors that predispose patients to death. With new discoveries in cancer biology, the pathological and biological prognostic factors of HCC have been studied quite extensively. Analyzing molecular markers (biomarkers) with prognostic significance is a complementary method. A large number of molecular factors have been shown to associate with the invasiveness of HCC, and have potential prognostic significance. One important aspect is the analysis of molecular markers for the cellular malignancy phenotype. These include alterations in DNA ploidy, cellular proliferation markers (PCNA, Ki-67, Mcm2, MIB1, MIA, and CSE1L/CAS protein), nuclear morphology, the p53 gene and its related molecule MDM2, other cell cycle regulators (cyclin A, cyclin D, cyclin E, cdc2, p27, p73), oncogenes and their receptors (such as ras, c-myc, c-fms, HGF, c-met, and erb-B receptor family members), apoptosis related factors (Fas and FasL), as well as telomerase activity. Another important aspect is the analysis of molecular markers involved in the process of cancer invasion and metastasis. Adhesion molecules (E-cadherin, catenins, serum intercellular adhesion molecule-1, CD44 variants),

proteinases involved in the degradation of extracellular matrix (MMP-2, MMP-9, uPA, uPAR, PAI), as well as other molecules have been regarded as biomarkers for the malignant phenotype of HCC, and are related to prognosis and therapeutic outcomes. Tumor angiogenesis is critical to both the growth and metastasis of cancers including HCC, and has drawn much attention in recent years. Many angiogenesis-related markers, such as vascular endothelial growth factor (VEGF), basic fibroblast growth factor (bFGF), platelet-derived endothelial cell growth factor (PD-ECGF), thrombospondin (TSP), angiogenin, pleiotrophin, and endostatin (ES) levels, as well as intratumor microvessel density (MVD) have been evaluated and found to be of prognostic significance. Body fluid (particularly blood and urinary) testing for biomarkers is easily accessible and useful in clinical patients. The prognostic significance of circulating DNA in plasma or serum, and its genetic alterations in HCC are other important trends. More attention should be paid to these two areas in future. As the progress of the human genome project advances, so does a clearer understanding of tumor biology, and more and more new prognostic markers with high sensitivity and specificity will be found and used in clinical assays. However, the combination of some items, i.e., the pathological features and some biomarkers mentioned above, seems to be more practical for now (17, 18, 29).

The medical consequences of HCV are tremendous. Our review indicate that vaccines should be developed to reduce the hepatocellular carcinoma and associated with HCV infection. We have studied immune response to DNA vaccine plasmid encoding core gene with unmethylated CpG motifs in the form of oligodeoxynucleotides as adjuvants for vaccination against hepatitis C. Our study demonstrates that CpG motifs enhance in vivo antibody levels to Hepatitis C virus core protein after DNA immunization (38, 39).

References

1. Chen SL, Morgan TR. The natural history of hepatitis C virus (HCV) infection. *Int J Med Sci.* 2006; **3**: 47-52.
2. Alavian SM, Einollahi B, Hajarizadeh B, Bakhtiari S, Nafar M, Ahrabi S: Prevalence of hepatitis C virus infection and related risk factors among Iranian hemodialysis patients. *Nephrology* 2003, **8**: 256-260.
3. Kabir A, Alavian SM, Keyvani H. Distribution of hepatitis C virus genotypes in patients infected by different sources and its correlation with clinical and virological parameters: a preliminary study. *Comp Hepatol.* 2006; **2**:4.
4. Alavian SM, Gholami B, Masarrat S. Hepatitis C risk factors in Iranian volunteer blood donors: a case control

- study. *J Gastroenterol Hepatol.* 2002; **17**:1092-7.
5. Volker Brass, Zhong J, Gastaminza P and *et al.* Molecular Virology of Hepatitis C Virus (HCV). *Int. J. Med. Sci.* 2006; **3**: 29-34.
 6. Choo QL, Richman KH, Han JH and *et al.* Genetic organization and diversity of the hepatitis C virus. *Proc. nat. Acad. Sci.* 1991; **88**: 2451-2455.
 7. Brass V, Moradpour D, Blum HE. Molecular Virology of Hepatitis C Virus (HCV): 2006 Update. *Int J Med Sci.* 2006; **3**: 29-34.
 8. Kiwamu Okita. Clinical aspects of hepatocellular carcinoma in Japan. *Intern Med.* 2006; **45**: 229-33
 9. Kenneth E. Drazan. Molecular Biology of Hepatitis C Infection. *Liver Transplantation*, 2000; **6**: 396-406
 10. Snorri S. Thorgeirsson1 and Joe W. Grisham. Molecular pathogenesis of human hepatocellular carcinoma. *Nature Genetics.* 2002, **31**, 339-346
 11. Pang R, Tse E, Poon RT. Molecular pathways in hepatocellular carcinoma. *Cancer Lett.* 2006; **240**: 157-69.
 12. Michielsen PP, Francque SM and van Dongen JL. Viral hepatitis and hepatocellular carcinoma. *World J Surg Oncol.* 2005; **3**: 27.
 13. Thomas MB and Abbruzzese JL. Opportunities for targeted therapies in hepatocellular carcinoma. *J Clin Oncol.* 2005; **23**: 8093-108.
 14. Nita ME, Alves VA, Carrilho FJ and *et al.* Molecular aspects of hepatic carcinogenesis. *Rev Inst Med Trop Sao Paulo.* 2002; **44**: 39-48.
 15. Qin LX, Tang ZY. Recent progress in predictive biomarkers for metastatic recurrence of human hepatocellular carcinoma: a review of the literature. *J Cancer Res Clin Oncol.* 2004; **130**: 497-513.
 16. Clevers H. Axin and hepatocellular carcinomas. *Nature Genet.* 2000; **24**: 206-208.
 17. Lun-Xiu Qin and Zhao-You Tang. The prognostic molecular markers in hepatocellular carcinoma. *World J Gastroenterol.* 2002; **8**: 385-392
 18. Kato N, Yoshid H, Ono-nita SK and *et al.* Activation of intracellular signaling by hepatitis B and C viruses C-viral core is the most potent signal inducer. *Hepatology.* 2000; **32**: 405-412.
 19. Cai Z, Zhang C, Chang KS and *et al.* Robust production of infectious hepatitis C virus (HCV) from stably HCV cDNA-transfected human hepatoma cells. *J Virol.* 2005; **79**: 3963-73
 20. Street A, Macdonald A, McCormick C and *et al.* Hepatitis C virus NS5A-mediated activation of hosphoinositide 3-kinase results in stabilization of cellular beta-catenin and stimulation of beta-catenin-responsive transcription. *J Virol.* 2005; **79**: 5006-5008
 21. Street A, Macdonald A, Crowder K and *et al.* The Hepatitis C virus NS5A protein activates a phosphoinositide 3-kinase-dependent survival signaling cascade. *J Biol Chem.* 2004; **279**: 12232-41.
 22. Karen E. Reed, Jian XU and Charles M. Rice. Phosphorylation of the Hepatitis C Virus NS5A Protein In Vitro and In Vivo: Properties of the NS5A-Associated Kinase. *Journal of Virology* 1997: 7187-7197
 23. Breuhahn K, Vreden S, Haddad R and *et al.* Molecular profiling of human hepatocellular carcinoma defines mutually exclusive interferon regulation and insulin-like growth factor II overexpression. *Cancer Res.* 2004; **64**: 6058-64.
 24. Majumder M, Ghosh AK, Steele R and *et al.* Hepatitis C virus NS5A physically associates with p53 and regulates p21/waf1 gene expression in a p53-dependent manner. *J Virol.* 2001; **75**: 1401-7.
 25. Yan XB, Chen Z, Luo DH and *et al.* Proapoptotic and pronecrosis effect of different truncated hepatitis C virus core proteins. *J Zhejiang Univ Sci B.* 2005; **6**: 295-300.
 26. Chung RT, He W, Saquib A, and *et al.* Hepatitis C virus replication is directly inhibited by IFN-alpha in a full-length binary expression system. *Proc Natl Acad Sci USA.* 2001; **98**: 9847-52.
 27. Neelima Jain, BK Tripathy, B Gupta. Hepatitis C Virus Infection: Natural History and Long Term Complications. *Journal, Indian Academy of Clinical Medicine.* 2000, **5**: 38-41.
 28. Akamatsu M, Yoshida H, Shiina S and *et al.* Sustained viral response prolonged survival of patients with C-viral hepatocellular carcinoma. *Liver Int.* 2006, **26**: 536-42.
 29. Ikeda M, Fujiyama S, Tanaka M and *et al.* Risk factors for development of hepatocellular carcinoma in patients with chronic hepatitis C after sustained response to interferon. *J Gastroenterol.* 2005; **40**: 220-2.
 30. Patel T, Dangell C, Maheshwari S. Impact of age on screening and surveillance for primary liver cancer. *Am J Gastroenterol.* 2006, **101**: 768-74.
 31. Alonso Alonso P, Orduna A, San Miguel A and *et al.* Genotypes of hepatitis C virus: their relationship with risk factors, the severity of liver disease, and the serologic response. *Med Clin.* 1999; **112**: 119.
 32. Mirmomen S, Alavian SM, Hajarizadeh B and *et al.* Epidemiology of hepatitis B, hepatitis C, and human immunodeficiency virus infections in patients with beta-thalassemia in Iran: a multicenter study. *Arch Iran Med.* 2006: 319-23.
 33. Tanaka H, Nouse K, Kobashi H and *et al.* Surveillance of hepatocellular carcinoma in patients with hepatitis C virus infection may improve patient survival. *Liver Int.* 2006: 543-51.
 34. Kang IK, Kim SW, Hahn SH and *et al.* A comparison of patients with hepatocellular carcinoma between a short-term (less than 6 months) survival group and a long-term (over 24 months) survival group after treatment with transcatheter arterial chemoembolization. *Taehan Kan Hakhoe Chi.* 2002; **8**: 189-200.
 35. Alonso Alonso P, Orduna A, San Miguel A and *et al.* Relation of hepatitis C virus genotypes to risk factors and hepatic disease in Spanish patients. *Clin Microbiol Infect.* 1997; **3**: 647-652.
 36. Garcia F, Roldan C, Garcia F Jr and *et al.* Subtype distribution among intravenous drug users with chronic type C hepatitis in southern Spain. *Microbios.* 1998; **95**:15-24.
 37. Zhang JY, Dai M, Wang X and *et al.* A case-control study of hepatitis B and C virus infection as risk factors for hepatocellular carcinoma in Henan, China. *Int J Epidemiol.* 1998; **27**: 574-8.
 38. Khatami F, Karami A, Sarbolouki MN, Sanati MH. Immunization of a recombinant plasmid encoding hepatitis C virus core protein. *Journal of Gastroenterology and Hepatology.* 2006, **21** A97.
 39. Karami A, Sarbolouki MN, Khatami F and Rastgoo N. CpG motif as an adjuvant in immunization of a recombinant plasmid encoding hepatitis C virus core protein. *Iranian J of Biotechnology,* 2005, **3**: 64-66.