



## Assessment of Antibacterial Capability of Rhamnolipids Produced by Two Indigenous *Pseudomonas aeruginosa* Strains

Tayebe Bagheri Lotfabad<sup>1</sup>, Fereshteh Shahcheraghi<sup>2\*</sup>, Fahimeh Shooraj<sup>2</sup>

<sup>1</sup>National Institute of Genetic Engineering and Biotechnology, Tehran, IR Iran

<sup>2</sup>Department of Bacteriology, Pasteur Institute of Iran, Tehran, IR Iran

### ARTICLE INFO

Article type:  
Original Article

Article history:  
Received: 09 Oct 2011  
Revised: 05 Jan 2012  
Accepted: 29 Apr 2012

Keywords:  
Rhamnolipid  
Biosurfactant  
*Pseudomonas aeruginosa*

### ABSTRACT

**Background:** In recent decades, biological properties of biosurfactants, particularly glycolipids, including antimicrobial, antifungal, and anti-cellular effects have been projected in many research studies. The unique advantages of these compounds in terms of production and environment made them important as antimicrobial agents.

**Objectives:** This study aims to evaluate probable antibacterial and antifungal properties of MR01 and MASH1 biosurfactants against several specified microorganisms.

**Materials and Methods:** In this article antibacterial activities of two rhamnolipid mixtures of MR01 and MASH1 were studied. MR01 and MASH1 are glycolipid-type biosurfactants that are being produced by two strains of *Pseudomonas aeruginosa* MR01 and MASH1, respectively. Antibacterial effects of two biosurfactants were assessed by disc diffusion test method and determination of minimum inhibitory concentration (MIC).

**Results:** They exhibit not only excellent surface activity but also remarkable inhibitory effect against Gram-positive bacteria. According to results, although none of two biosurfactants showed significant effects on Gram negative bacteria growth inhibition, both assessing methods confirmed the growth inhibition of Gram-positive bacteria by MR01 and MASH1 biosurfactants.

**Conclusions:** According to results of this study, MR01 and MASH1 biosurfactants had antimicrobial efficacy against Gram positive bacterial groups. This effect is comparable to antibiotics and therefore the future use of these biosurfactants as broad spectrum antibiotics is highly promising. These features of biosurfactants (BS) should broaden its applications in new advanced technologies.

Future studies will be performed on characterization and isolation of biologically active fraction of the rhamnolipid biosurfactant produced by *P. aeruginosa* strains. This bioactive compound may be evaluated as a potent antimicrobial agent to be applied against a panel of pathogenic micro-organisms including a few multidrug-resistant (MDR) clinical pathogenic isolates such as methicillin-resistant *Staphylococcus aureus* (MRSA) and other MDR pathogenic strains.

Published by Kowsar Corp, 2013. cc 3.0.

### ► Implication for health policy/practice/research/medical education:

This study shows that rhamnolipid mixtures of MR01 and MASH1 have antimicrobial efficacy against Gram positive bacteria and may be evaluated as antimicrobial agent against multidrugresistant clinical pathogenic isolates.

### ► Please cite this paper as:

Bagheri Lotfabad T, Shahcheraghi F, Shooraj F. Assessment of Antibacterial Capability of Rhamnolipids Produced by Two Indigenous *Pseudomonas aeruginosa* Strains. *Jundishapur J Microbiol.* 2013;6(1):29-35. DOI: 10.5812/jjm.2662

\* Corresponding author: Fereshteh Shahcheraghi, Pasteur Institute of Iran, Pasteur Street, Tehran, IR Iran. Tel/Fax: +98-2166405535, E-mail: ShahcheraghiFereshteh@yahoo.com

## 1. Background

For the first time in 1949, it was reported that crystalline glycolipid isolated from *Pseudomonas aeruginosa* showed antibiotic activity against tuberculosis in mice (1). At that time, there was little knowledge about biosurfactants and enormous capabilities of these compounds. Several decades later, in a world based on green technology as a foundation of the search for sustainable development, biological compounds were being recognized increasingly as an alternative to their synthetic counterparts because of characteristics such as mild process conditions, low toxicity, high biodegradability, and environmental compatibility (2-8). Biological surfactants (biosurfactants) are an example of such compounds.

Biosurfactants are produced by diverse microorganisms to fulfill various natural functions. They exhibit a broad spectrum of chemical structures such as glycolipids, lipopeptides and lipoproteins, lipopolysaccharides, phospholipids, fatty acids, and polymeric lipids (9, 10). Therefore, it is reasonable to expect various properties and physiological functions for biosurfactants such as reducing surface and interfacial tensions as well as increasing surface area and bioavailability of hydrophobic water-insoluble compounds, heavy metal binding, bacterial pathogenesis, quorum sensing, and biofilm formation (11). Due to their ability to dissolve or disperse hydrophobic compounds in water, biosurfactants have prompted in food, pharmaceutical, and cosmetic applications as well as in crop protection, environmental industries, energy-saving technologies, and so on (2-5, 7, 8, 12, 13).

Some of interesting features of biosurfactants have led to a wide range of potential applications in the medical field. They are useful as antibacterial, antifungal, and antiviral agents (14). Particularly, these products are highly valued for their antimicrobial activities and lack of toxicity (15). The antimicrobial activity of several biosurfactants has been reported in the literature for various applications (16).

Different types of biosurfactants have shown antimicrobial actions against bacteria, fungi, algae, and viruses. The lipopeptide iturin from *Bacillus subtilis* showed potent antifungal activity (17). Inactivation of enveloped viruses such as herpes virus and retrovirus was observed by 80 microM of surfactin (18). Rhamnolipids inhibited the growth of harmful bloom algae species, *Heterosigma akashivo*, and *Prorocentrum dentatum* at concentrations ranging from 0.4 to 10.0 mg/l. A rhamnolipid mixture obtained from *P. aeruginosa* AT10 showed bacterial inhibiting activity against *Escherichia coli*, *Micrococcus luteus*, *Alcaligenes faecalis* (32 mg/mL), *Serratia marcescens*, *Mycobacterium phlei* (16 mg/mL) and *Staphylococcus epidermidis* (8 mg/mL), and excellent antifungal properties against *Aspergillus niger* (16 mg/mL), *Chaetomium globosum*, *Penicillium chrysogenum*, *Aureobasidium pullulans* (32 mg/mL),

and phytopathogenic *Botrytis cinerea* and *Rhizoctonia solani* (18 mg/mL) (19). Sophorolipids and rhamnolipids were found to be effective antifungal agents against plant and seed pathogenic fungi. The mannosylerythritol lipid (MEL), a glycolipid surfactant from *Candida antarctica*, has demonstrated antimicrobial activity particularly against Gram-positive bacteria (20).

Biosurfactants appears to be great potential and suitable alternatives to synthetic medicines and antimicrobial agents and may be used as safe and effective therapeutic agents (3, 11, 14, 21). Glycolipids are the most promising among biosurfactants due to high productivity from renewable resources and versatile biochemical properties (2-8). There have been many previous studies on antimicrobial activities of rhamnolipids produced by *P. aeruginosa* strains and they were known to exhibit this feature activity (19, 22-24).

## 2. Objectives

This study specifically aimed to compare antibacterial effects of biosurfactants produced by different *P. aeruginosa* strains isolated from different sources when grown on different carbon sources. MR01 and MASH1 strains were isolated from two oil excavation areas in south of Iran.

## 3. Materials and Methods

### 3.1. Biosurfactants and Test Microorganisms

MR01 biosurfactant produced by *P. aeruginosa* MR01 with GenBank accession number of EU795302 in M1 medium using glucose as sole carbon source was purified as described in previous work (25).

MASH1 biosurfactant produced by MASH1 (26) using soybean oil as sole carbon source was cultivated in SOM medium composed of (g/L):  $\text{NaNO}_3$  3.0,  $\text{KH}_2\text{PO}_4$  0.25,  $\text{MgSO}_4 \cdot 7\text{H}_2\text{O}$  0.25, yeast extract 1.0 and soybean oil 10. Seed cultures were prepared using a seed culture medium containing (g/L): glucose 40,  $\text{NaNO}_3$  3.0,  $\text{KH}_2\text{PO}_4$  0.25,  $\text{MgSO}_4 \cdot 7\text{H}_2\text{O}$  0.25 and yeast extract 1.0 by overnight incubation on rotary shaker at 200 rpm and 30 °C. Seed cultures were inoculated (2% v/v) in 250 ml flasks containing 50 ml of production medium followed by incubation at 200 rpm and 30 °C for 6 days. Crude biosurfactant was obtained using an acid precipitation and solvent extraction method (27, 28). At the end of incubation, cells were removed from the culture broth by centrifugation at 10000 × g for 15 min at 4 °C. The cell free supernatant was acidified with 6 N HCl to pH 2 and stored overnight at 4 °C to enhance precipitation of biosurfactant. Then it was centrifuged (18000 × g, 30 min, 4 °C) and the resultant precipitate was extracted several times with ethyl acetate at room temperature. The solvent was completely evaporated under vacuum. The crude biosurfactant was obtained as a viscose brown-

colored material (26).

The microorganisms used in this study included laboratory control strains of *Streptococcus pneumoniae* (clinical sample), *S. epidermidis* (ATCC 12228), *S. aureus* (ATCC 29213), *B. subtilis* (ATCC 6051), *B. cereus* (PTCC1247), *Enterococcus faecalis* (ATCC 29212), *E. faecalis* (clinical sample) and *Micrococcus luteus*, (clinical sample) as Gram-positive bacteria. *Salmonella typhi* (ATCC19430), *Klebsiella pneumoniae* (clinical sample), *Klebsiella pneumoniae* (ATCC 7881), *E. coli* (clinical sample), *E. coli* (ATCC 25922), *E. coli* K12 (clinical sample) and *P. aeruginosa* (ATCC 27853) as Gram-negative bacteria were obtained from Department of Bacteriology, Pasteur Institute of Iran, Tehran, Iran.

Evaluated fungal strains were *A. niger* ATCC 14604, *A. pululans* ATCC 9348, *C. globosum* ATCC 6205, *P. chrysogenum* CECT 2802, and *P. funiculosum* CECE 2914.

### 3.2. Evaluation of Antibacterial Effects by Disc Diffusion Method

The antibacterial effects of MR01 and MASH1 biosurfactant samples were assessed separately in every 3 concentrations of 10, 20, and 30 mg/ml on *E. coli* ATCC 25922, *P. aeruginosa* ATCC 27853, *S. aureus* ATCC 29213, *S. epidermidis* ATCC 12228, and *B. subtilis* ATCC 6051.

The Kirby-Bauer disc diffusion susceptibility test (28) performed in accordance to Clinical and Laboratory Stan-

dards Institute (CLSI) 6mm discs containing 30 $\mu$ l of the different dilutions of two biosurfactant samples were applied to the surface of medium. The plates were incubated at 35°C aerobically (no CO<sub>2</sub>) for 16-18 h. Then each plate was examined and diameters of the zones of complete inhibition, together with diameter of the disk were measured.

### 3.3. Evaluation of Antibacterial Effects Using Minimal Inhibition Concentration (MIC) Method

Antimicrobial activity was determined on the basis of minimal inhibition concentration (MIC) values, defined as the lowest concentration of antimicrobial agent needed to inhibit the development of visible growth after incubation for the required time. A standard two-fold serial rhamnolipid dilution technique was applied to measure antimicrobial activity (29). Briefly, a 10 mg/ml stock solution of MR01 and MASH1 biosurfactants in Muller Hinton broth containing Ca<sup>2+</sup>, Mg<sup>2+</sup> was diluted twofold to concentrations ranging from 0.25 to 512  $\mu$ g/ml (Figure 1).

Antibacterial activity was determined on 15 bacterial suspensions (Table 1 and Table 2).

For each strain tested, one colony with typical morphology was selected from an agar plate that had been incubated overnight and inoculated into the Muller Hinton broth containing Ca<sup>2+</sup>, Mg<sup>2+</sup> which was incubated in

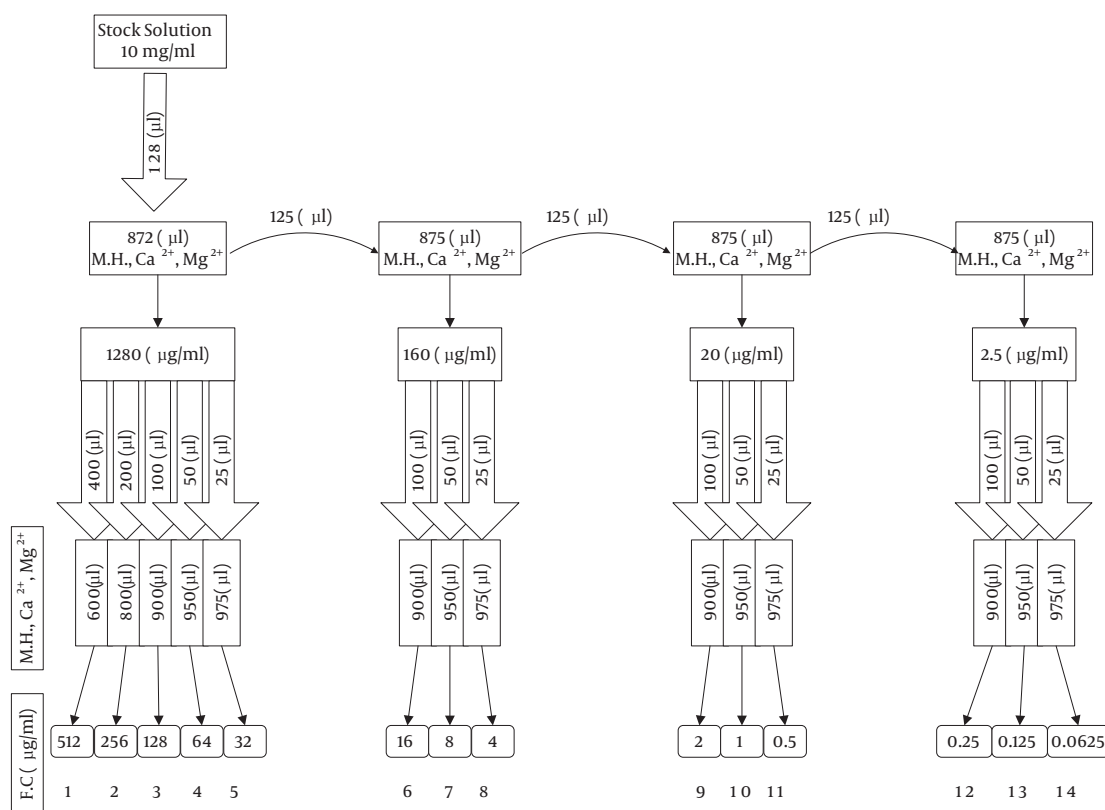

**Figure 1.** Preparing Twofold Serial Dilution (M.H.= Muller Hinton Broth, F.C = Final Concentration).

**Table 1.** Disc Diffusion Susceptibility of Biosurfactant Produced by MR01 and MASH1 Strains Using Glucose and Soybean Oil as Sole Carbon Source, Respectively.

Bacteria	Code	Zone Inhibition Diameters (nearest whole mm)		
		Biosurfactant Concentration, mg/mL, MR01, MASH1		
		10	20	30
<b>Gram positive</b>				
<i>Staphylococcus aureus</i>	ATCC 29213	14 ± 1, 20 ± 2	15 ± 2, 20 ± 2	15, 20 ± 2
<i>Staphylococcus epidermidis</i>	ATCC 12228	15 ± 2, 20 ± 3	15 ± 2, 20 ± 2	15 ± 2, 20 ± 3
<i>Bacillus cereus</i>	ATCC 6051	30 ± 3, 30 ± 2	30 ± 3, 30 ± 2	30 ± 3, 30 ± 2
<b>Gram negative</b>				
<i>Escherichia coli</i>	ATCC 25922	0, 0	0, 0	0, 0
<i>Pseudomonas aeruginosa</i>	ATCC 27853	0, 0	0, 0	0, 0

**Table 2.** Minimum Inhibitory Concentration Results

Bacteria	Code	MIC(μg/mL)	
		MR01	MASH1
<b>Gram positive</b>			
<i>Streptococcus pneumonia</i>	(clinical sample)	128	128
<i>Staphylococcus epidermidis</i>	(clinical sample)	128	64
<i>Staphylococcus aureus</i>	ATCC 29213	128	512
<i>Bacillus subtilis</i>	ATCC 6051	128	128
<i>Bacillus cereus</i>	PTCC1247	128	64
<i>Enterococcus faecalis</i>	ATCC 29212	> 512	64
<i>Enterococcus faecalis</i>	(clinical sample)	> 512	64
<i>Micrococcus luteus</i>		32	64
<b>Gram negative</b>			
<i>Salmonella typhi</i>	ATCC 19430	> 512	> 512
<i>Klebsiella pneumonia</i>	(clinical sample)	> 512	> 512
<i>Klebsiella pneumonia</i>	ATCC 7881	> 512	> 512
<i>Escherichia coli</i>	(clinical sample)	> 512	> 512
<i>Escherichia coli</i>	ATCC 25922	> 512	> 512
<i>Escherichia coli</i> K12		> 512	> 512
<i>Pseudomonas aeruginosa</i>	ATCC 27853	> 512	> 512

Muller-Hinton broth at 37°C for 12 h. The cell density of the cultures was adjusted to approximately  $1 \times 10^8$  cfu/mL, equivalent to an absorbance reading at 650 nm of 0.7 and then diluted in normal saline as showed in Figure 2.

Broth microdilution testing was performed with 96-well, round-bottom microtiter plates. Each plate included positive controls (bacterial suspension without antimicrobial agent), negative controls (medium only), and serial twofold dilutions of biosurfactant samples (the antimicrobial agents). Antimicrobial-containing wells included 5 μL of this bacterial suspension and 100 μL of final concentrations of MR01 biosurfactant, ranging from 0.25 to 512 μg/mL. Microplate containing test and control wells was incubated at 37°C for 18 h. MICs were evaluated in four separate experiments.

### 3.4. Evaluation of Antifungal Activity Using Growth Inhibition Method

Antimicrobial activity of MR01 and MASH1 biosurfac-

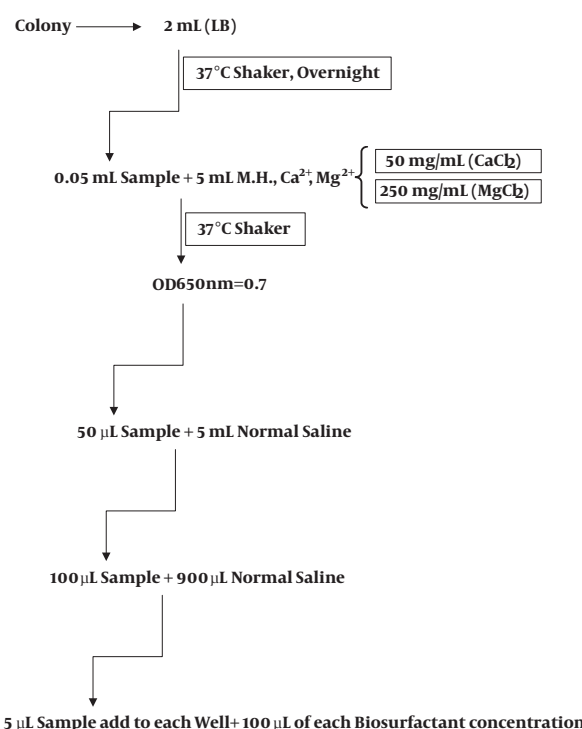
**Figure 2.** Microdilution of Bacterial Suspension

tants was detected on the basis of minimal inhibition concentration (MIC) values, defined as the lowest concentration of antimicrobial agent needed to inhibit the development of visible growth after incubation for the required time. Antimicrobial activity against fungi was accomplished on solid medium Sabouraud agar plates which were incubated for 72 h at 25°C (30).

## 4. Results

Disc diffusion data for susceptibility of test strains against MR01 and MASH1 biosurfactant has been represented in Table 1. Table 2 shows the comparison of MIC results of biosurfactants produced by MR01 and MASH1 strains against different Gram positive and Gram nega-



tive bacteria. The results for inhibitory activities of MR01 and MASH1 biosurfactants against several reference fungal strains have been shown in Table 3.

**Table 3.** Minimal Inhibitory Concentration (MIC) of MR01 and MASH1 Biosurfactants Against Selected Fungi.

Fungi	Code	MIC, $\mu\text{g/mL}$	
		MR01	MASH1
<i>Aspergillus niger</i>	ATCC 14604	64	128
<i>Aureobasidium pullulans</i>	ATCC 9348	128	128
<i>Chaetonium globosum</i>	ATCC 6205	64	32
<i>Penicillium chrysogenum</i>	CECT 2802	> 256	128
<i>Penicillium funiculosum</i>	CECE 2914	32	32

## 5. Discussion

Preliminary disc diffusion data summarized in Table 1, showed that all examined Gram positive bacteria (i.e. *S. aureus* ATCC 29213, *S. epidermidis* ATCC 12228 and *B. cereus* ATCC 6051) were inhibited by biosurfactants produced by both MR01 and MASH1 strains. MASH1 Growth of *S. aureus* ATCC 29213 and *S. epidermidis* ATCC 12228 were inhibited by MASH1 biosurfactant more than that by MR01 biosurfactant (exhibiting zone inhibition diameters  $20 \pm 2$  and  $15 \pm 2$  mm, respectively), While the inhibitory effects of both biosurfactants for *B. cereus* ATCC 6051 were similar. In this experiment both biosurfactants in different concentrations exhibited good antibacterial effects on Gram positive bacteria. None of examined Gram negative bacteria were affected by the MR01 and MASH1 biosurfactants produced from different carbon sources (Table 1).

Regarding Table 2, none of biosurfactants affected the growth of Gram negative bacteria which confirmed the results of our preliminary tests based on disc diffusion method. On the other hand, MR01 and MASH1 biosurfactants showed different antimicrobial activity behaviors on Gram positive bacteria. The MIC values of MR01 biosurfactant for *S. epidermidis* ATCC 12228, *B. cereus* PTCC1247, *E. faecalis* ATCC 29212, and *E. faecalis* (clinical sample) were higher than that of MASH1 biosurfactant. Growth of both *E. faecalis* strains inhibited at the presence of MASH1 biosurfactant at approximately low concentration (64  $\mu\text{g/mL}$ ), while MR01 biosurfactant couldn't inhibit the growth of those bacteria at concentration below 512  $\mu\text{g/mL}$ . MIC values of MR01 for *S. aureus* ATCC 29213 and *M. luteus* (clinical sample) were lower than that of MASH1 biosurfactant and respective values for *Streptococcus pneumoniae* (clinical sample) and *B. subtilis* ATCC 6051 were equal for both biosurfactants (Table 2). The results of the second method (MIC) were more delicate than the former because in the latter, the sensitivity was high and number of tested bacteria was increased.

Gram positive bacteria studied in this work were more susceptible to both biosurfactant samples than Gram negative ones. It means that examined biosurfactants

were more active against Gram-positive bacteria than against Gram-negative ones (Table 2). This is an important finding as there is still little information about antimicrobial activity of surfactants.

Several structural rhamnolipid congeners produced by different strains of *P. aeruginosa* have been identified so far (22, 30-32). The type of rhamnolipid produced depends on the bacterial strain, the carbon source used, and the process strategy (24, 33, 34). Rhamnolipids are formed by one or two rhamnose molecules linked to one or two fatty acids of saturated or unsaturated alkyl chain between  $C_8$  and  $C_{12}$  (35). New analytical methods of high-performance liquid chromatography and mass spectrometry (HPLC-MS) have identified numerous congeners which contain one or two rhamnose molecules and one or two residues of 3-hydroxydecanoic acid groups (30-32, 34, 36, 37). Even 3-hydroxydodecanoic and 3-hydroxytetradecanoic acid residues have been reported (34, 36).

Similar results for being more effective on Gram positive bacteria than that on Gram negative ones were previously reported for glycolipid biosurfactant of MEL by Kitamoto *et al.* (20). and rhamnolipid biosurfactant of *P. aeruginosa* AT10 by Haba *et al.* (37). Relying on therapeutic applications of some biosurfactants as antibiotics and antifungal or antiviral compounds, some of researchers studied on several surfactant-resistant strains and isolated sensitive strains of bacteria by artificial or spontaneous mutagenesis and concerned this phenomenon to possess altered structures and functions in their cell membranes (38, 39).

Yilmaz and Sidal reported that the antimicrobial activity against Gram positive bacteria was more potent than against Gram negative bacteria. They supposed that mechanism of antimicrobial action of rhamnolipid biosurfactant regards to the fact that biosurfactants may disturb membrane structure through interaction with phospholipids as well as membrane proteins. Biological function of biosurfactants has not been completely understood yet; e.g., these substances, when excreted into the medium, emulsify hydrocarbons, and when located in cell wall structure, facilitate the penetration of hydrocarbons to periplasmic space (40). Onbasli *et al.* studied relationship between antimicrobial activity and rhamnolipid production and explained observed findings by hardly permeable characteristic of Gram negative bacteria membranes to hydrophobic and amphipathic molecules. It is well-known that Gram positive and Gram negative bacteria have different cell wall chemical structures (41).

According to disc diffusion and MIC results, both biosurfactants had no significant effects on Gram-negative bacteria; this finding was rather different with previous results reported by Haba *et al.* about effects of rhamnolipids produced by *P. aeruginosa* 47T2 NCBIM 40044 on Gram negative bacteria (22). The variation observed in

results may be attributed to the differences in homologous composition of the rhamnolipid mixtures evaluated. When Haba *et al.* compared antimicrobial activities of two rhamnolipid mixtures obtained from different *P. aeruginosa* strains, they observed that *P. aeruginosa* AT10 rhamnolipids were most effective against fungi, and *P. aeruginosa* 47T2 rhamnolipids was more efficient against bacteria. The effects observed were attributed to differences in homologue composition of both rhamnolipid mixtures (22).

Owing to their intrinsic properties, surface-active compounds interfere with cell surfaces and disrupt microbial membranes. Despite that there are many studies in relation to antimicrobial potency of rhamnolipids (19, 22-24, 41, 42), still there is little information about antimicrobial action mechanisms of rhamnolipid biosurfactants, nature and limitations of antibacterial spectrum of natural rhamnolipid congeners, and contribution of each homologous species in final activity of the product (24). To our best knowledge, there are few reports in the literature on the physicochemical characterization and biological activity of rhamnolipid mixtures to be used as a single product. The properties of such a product depend on the type and proportion of homologous (19).

In our another study, HPLC-ES-MS in negative mode was used to identify rhamnolipid congeners produced by *P. aeruginosa* MR01. By performing this technique, up to 17 different rhamnolipid congeners were recognized in MR01 biosurfactant mixture when grown on glucose in M1 medium using glucose as sole carbon source (43). *P. aeruginosa* MR01, grown in M1 medium, produced a mixture of rhamnolipids with capability of surface tension reduction to 27 mN/m. *P. aeruginosa* MR01 produced several biosurfactants. MASH1 strain produced up to 6 different rhamnolipid congeners using soybean oil as sole carbon source (data not published). The different observed antibacterial effects against Gram positive bacteria for MR01 and MASH1 may be related to the differences in the culture medium composition, isolation source, carbon source, etc. MR01 was isolated from crude oil and produced biosurfactant using glucose as sole carbon source on M1 minimal salt medium at 37°C, while MASH1 was isolated from other crude oil reservoir (26) and produced biosurfactant using soybean oil as sole carbon source at 30°C. These conditions may change the structure of biosurfactant produced by different strains and lead to different behavior of antibacterial properties of biosurfactants.

Regarding data shown in Table 3, high activity against *C. globosum* and *P. funiculosus* was observed by two MR01 and MASH1 biosurfactants but none of them was found to be effective on *A. pullulans* and *P. chrysogenum*. Indeed, MR01 and MASH1 biosurfactants exhibited different inhibitory behaviors against *A. niger*. MIC values obtained for MR01 and MASH1 biosurfactants against examined

aforementioned fungi were slightly different with which reported by others (19, 22-23). It is supposed that the difference might be attributed to differences in homologous composition of rhamnolipid mixtures evaluated.

## Acknowledgments

None declared.

## Financial Disclosure

None declared.

## Funding/Support

None declared.

## Authors' Contribution

None declared.

## References

- Jarvis FG, Johnson MJ. A glyco-lipide produced by *Pseudomonas Aeruginosa*. *J American Chem Soc.* 1949;**71**(12):4124-6.
- Cameotra SS, Makkar RS. Synthesis of biosurfactants in extreme conditions. *Appl Microbiol Biotechnol.* 1998;**50**(5):520-9.
- Banat IM, Makkar RS, Cameotra SS. Potential commercial applications of microbial surfactants. *Appl Microbiol Biotechnol.* 2000;**53**(5):495-508.
- Kitamoto D, Isoda H, Nakahara T. Functions and potential applications of glycolipid biosurfactants - from energy-saving materials to gene delivery carriers. *J Biosc Bioengin.* 2002;**94**(3):187-201.
- Cameotra SS, Makkar RS. Recent applications of biosurfactants as biological and immunological molecules. *Curr Opin Microbiol.* 2004;**7**(3):262-6.
- Kitamoto D. [Naturally engineered glycolipid biosurfactants leading to distinctive self-assembling properties]. *Yakugaku Zasshi.* 2008;**128**(5):695-706.
- Morita T, Fukuoka T, Imura T, Kitamoto D. Production of glycolipid biosurfactants by basidiomycetous yeasts. *Biotechnol Appl Biochem.* 2009;**53**(Pt 1):39-49.
- Kitamoto D, Morita T, Fukuoka T, Konishi M-a, Imura T. Self-assembling properties of glycolipid biosurfactants and their potential applications. *Curr Opin Colloid & Interface Sci.* 2009;**14**(5):315-28.
- Ahimou F, Jacques P, Deleu M. Surfactin and iturin A effects on *Bacillus subtilis* surface hydrophobicity. *Enzyme Microb Technol.* 2000;**27**(10):749-54.
- Maier RM, Soberon-Chavez G. *Pseudomonas aeruginosa* rhamnolipids: biosynthesis and potential applications. *Appl Microbiol Biotechnol.* 2000;**54**(5):625-33.
- Singh P, Cameotra SS. Potential applications of microbial surfactants in biomedical sciences. *Trends Biotechnol.* 2004;**22**(3):142-6.
- Klekner V, Kosaric Np-, editors. *Biosurfactants: Productions, Properties, Applications.* New York: Dekker; 1993.
- Banat IM. Characterization of biosurfactants and their use in pollution removal - State of the Art. (Review). *Acta Biotechnologica.* 1995;**15**(3):251-67.
- Rodrigues L, Banat IM, Teixeira J, Oliveira R. Biosurfactants: potential applications in medicine. *J Antimicrob Chemother.* 2006;**57**(4):609-18.
- Lang S, Wagner F. Biosurfactants and biotechnology. In: Kosaric N, Cairns W, Gray W, editors. *Structure and properties of biosurfactants.* New York: Marcel Dekker; 1987. p. 21-45.
- Muthusamy K, Gopalakrishnan S, Ravi TK, Sivachidambaram P. Biosurfactants: Properties, commercial production and application. *Curr Sci.* 2008;**94**(6):736-47.
- Besson F, Peypoux F, Michel G, Delcambe L. Characterization of

- iturin A in antibiotics from various strains of *Bacillus subtilis*. *J Antibiot*. 1976;**29**(10):1043-9.
18. Vollenbroich D, Ozel M, Vater J, Kamp RM, Pauli G. Mechanism of inactivation of enveloped viruses by the biosurfactant surfactin from *Bacillus subtilis*. *Biologicals*. 1997;**25**(3):289-97.
  19. Abalos A, Pinazo A, Infante MR, Casals M, Garcia F, Manresa A. Physicochemical and antimicrobial properties of new rhamnolipids produced by *Pseudomonas aeruginosa* AT10 from soybean oil refinery wastes. *Langmuir*. 2001;**17**(5):1367-71.
  20. Kitamoto D, Yanagishita H, Shinbo T, Nakane T, Kamisawa C, Nakahara T. Surface active properties and antimicrobial activities of mannosylerythritol lipids as biosurfactants produced by *Candida antarctica*. *J Biotechnol*. 1993;**29**(1-2):91-6.
  21. Das P, Mukherjee S, Sen R. Antimicrobial potential of a lipopeptide biosurfactant derived from a marine *Bacillus circulans*. *J Appl Microbiol*. 2008;**104**(6):1675-84.
  22. Haba E, Pinazo A, Jauregui O, Espuny MJ, Infante MR, Manresa A. Physicochemical characterization and antimicrobial properties of rhamnolipids produced by *Pseudomonas aeruginosa* 47T2 NCBIM 40044. *Biotechnol Bioeng*. 2003;**81**(3):316-22.
  23. Benincasa M, Abalos A, Oliveira I, Manresa A. Chemical structure, surface properties and biological activities of the biosurfactant produced by *Pseudomonas aeruginosa* LBI from soapstock. *Int J Gen Molecul Microb*. 2004;**85**(1):1-8.
  24. Nitschke M, Costa SG, Contiero J. Structure and applications of a rhamnolipid surfactant produced in soybean oil waste. *Appl Biochem Biotechnol*. 2010;**160**(7):2066-74.
  25. Lotfabad TB, Shourian M, Roostaazad R, Najafabadi AR, Adelzadeh MR, Noghabi KA. An efficient biosurfactant-producing bacterium *Pseudomonas aeruginosa* MR01, isolated from oil excavation areas in south of Iran. *Colloids Surf B Biointerfaces*. 2009;**69**(2):183-93.
  26. Afshar S, Lotfabad T, Roostaazad R, Najafabadi A, Noghabi K. Comparative approach for detection of biosurfactant-producing bacteria isolated from Ahvaz petroleum excavation areas in south of Iran. *Ann Microbiol*. 2008;**58**(3):555-9.
  27. Wei YH, Chou CL, Chang JS. Rhamnolipid production by indigenous *Pseudomonas aeruginosa* J4 originating from petrochemical wastewater. *Biochem Eng J*. 2005;**27**(2):146-54.
  28. Bauer A, Kirby W, Sherris J, Turck M. Antibiotic susceptibility testing by a standardized single disk method. *Am J Clin Pathol*. 1966;**45**(4):493-6.
  29. Woods GL, Washington JA. Antibacterial susceptibility tests: Dilution and disk diffusion methods. In: Murray PR, editor. *Manual of Clinical Microbiology*. Washington, DC: ASM Press; 1995. p. 1327-41.
  30. Gunther NWT, Nunez A, Fett W, Solaiman DK. Production of rhamnolipids by *Pseudomonas chlororaphis*, a nonpathogenic bacterium. *Appl Environ Microbiol*. 2005;**71**(5):2288-93.
  31. Monteiro SA, Sassaki GL, de Souza LM, Meira JA, de Araujo JM, Mitchell DA, et al. Molecular and structural characterization of the biosurfactant produced by *Pseudomonas aeruginosa* DAUPE 614. *Chem Phys Lipids*. 2007;**147**(1):1-13.
  32. Heyd M, Kohnert A, Tan TH, Nusser M, Kirschköfer F, Brenner-Weiss G, et al. Development and trends of biosurfactant analysis and purification using rhamnolipids as an example. *Analytic Bioanalytic Chem*. 2008;**391**(5):1579-90.
  33. Lang S, Wullbrandt D. Rhamnolipids-biosynthesis, microbial production and application potential. *Appl Microbiol Biotechnol*. 1999;**51**(1):22-32.
  34. Déziel E, Lépine F, Milot S, Villemur R. Mass spectrometry monitoring of rhamnolipids from a growing culture of *Pseudomonas aeruginosa* strain 57RP. *Biochimica et Biophysica Acta (BBA) - Mol Cell Biol Lipids*. 2000;**1485**(2-3):145-52.
  35. Rendell NB, Taylor GW, Somerville M, Todd H, Wilson R, Cole PJ. Characterisation of *Pseudomonas* rhamnolipids. *Biochimica et Biophysica Acta (BBA) - Lipids Lipid Metabol*. 1990;**1045**(2):189-93.
  36. Déziel E, Lépine F, Dennie D, Boismenu D, Mamer OA, Villemur R. Liquid chromatography/mass spectrometry analysis of mixtures of rhamnolipids produced by *Pseudomonas aeruginosa* strain 57RP grown on mannitol or naphthalene. *Biochimica et Biophysica Acta (BBA) - Mol Cell Biol Lipids*. 1999;**1440**(2-3):244-52.
  37. Haba E, Abalos A, Jauregui O, Espuny M, Manresa A. Use of liquid chromatography-mass spectroscopy for studying the composition and properties of rhamnolipids produced by different strains of *Pseudomonas aeruginosa*. *Journal of Surfactants and Detergents*. 2003;**6**(2):155-61.
  38. Vaara M. Increased outer membrane resistance to ethylenediaminetetraacetate and cations in novel lipid A mutants. *J Bacteriol*. 1981;**148**(2):426-34.
  39. Ishikawa S, Matsumura Y, Yoshizako F, Tsuchido T. Characterization of a cationic surfactant-resistant mutant isolated spontaneously from *Escherichia coli*. *J Appl Microbiol*. 2002;**92**(2):261-8.
  40. Yilmaz ES, Sidal U. Investigation of antimicrobial effects of a *Pseudomonas*-originated biosurfactant. *Biologia - Bratislava*. 2005;**60**:723-5.
  41. Onbasli D, Aslim B. Determination of antimicrobial activity and production of some metabolites by *Pseudomonas aeruginosa* B1 and B2 in sugar beet molasses. *African J Biotechnol*. 2008;**7**(24):4614-9.
  42. Haba E, Pinazo A, Jauregui O, Espuny MJ, Infante MR, Manresa A. Physicochemical characterization and antimicrobial properties of rhamnolipids produced by *Pseudomonas aeruginosa* 47T2 NCBIM 40044. *Biotechnol Bioengin*. 2003;**81**(3):316-22.
  43. Lotfabad TB, Abassi H, Ahmadvaniha R, Roostaazad R, Masoomi F, Zahiri HS, et al. Structural characterization of a rhamnolipid-type biosurfactant produced by *Pseudomonas aeruginosa* MR01: Enhancement of di-rhamnolipid proportion using gamma irradiation. *Colloids and Surfaces B: Biointerfaces*. 2010;**81**(2):397-405.